

# SO-SFP-GE-FE-LX-20

SFP, Gigabit Port, 100Mbps FE, 1310, SM, DDM, 17dB, 20km, SGMII Interface

## OVERVIEW

The SO-SFP-GE-FE-LX fiber optical SFP (Small Form Pluggable) transceivers include a PIN diode and a FP transmitter suitable for single-mode fiber transmission, like IEEE 100BASE-LX. The module has a build-in PHY device supporting SGMII interface.

Additionally, a build-in high performance MCU offers easy configuration of all functions from the host site. The module has a duplex LC optical interface and all mechanical characteristics are compliant with the current SFP specification (SFF-8431 and SFF-8432). All SFP modules fulfill the content of the serial EEPROM described in the SFP MSA, Appendix B4, table 3.1, at base data fields (defined as addresses 0 to 63) and extended data fields (defined as addresses 64 to 95). The nominal transmitter output wavelength is stated at the reserved addresses 60-61 according to SFF document SFF-8472 rev 10.4, "Digital Diagnostics Monitoring Interface".

Wavelengths stated in the specification are measured in vacuum. All requirements in this specification are valid throughout the specified lifetime and operational environmental temperature range unless otherwise stated. The transceiver modules are compliant to RoHS-6/6.

## PRODUCT FEATURES

- 100Base-LX compliant
- Build-in PHY supporting SGMII Interface
- Link status monitor, CRC Package Counter, Far End Fault Indication (FEFI)
- 1310nm Laser
- PIN Receiver
- Duplex LC connector
- Hot-pluggable SFP footprint
- Built-in digital diagnostic functions
- Up to 20km on 9/125um SMF (G.652)
- Single power supply 3.3V
- RoHS 6/6 compliant
- Class 1 laser product complies with EN 60825-1
- Operating temperature range
  - 0°C to 70°C (standard)
  - 20°C to +85°C (extended)

## ORDERING INFORMATION

Part Number	Description
SO-SFP-GE-FE-LX-20	SFP, Gigabit Port, 100Mbps FE, 1310, SM, 17dB, 20km, SGMII Interface
SO-SFP-GE-FE-LX-20-E	SFP, Gigabit Port, 100Mbps FE, 1310, SM, 17dB, 20km, SGMII Interface, Ext. temp

Subject to change without notice.

For more information, visit [smaroptics.com](http://smaroptics.com).

## APPLICATIONS

- 100Base-LX connectivity

## GENERAL SPECIFICATIONS

Parameter	Symbol	Min	Typ	Max	Unit	Remarks
Data Rate	DR		125		Mbps	
Bit Error Rate	BER			$10^{-12}$		
Operating Temperature	T <sub>OP</sub>	0		70	°C	Case temperature
		-40		+85		Extended temperature
Operating Relative Humidity				95	%	
Storage Temperature	T <sub>STO</sub>	-40		85	°C	Ambient temperature
Supply Current	I <sub>S</sub>		240	360	mA	For electrical power interface
Input Voltage	V <sub>CC</sub>	3.15	3.3	3.45	V	
Maximum Voltage	V <sub>MAX</sub>	-0.5		3.6	V	For electrical power interface

## OPTICAL CHARACTERISTICS – TRANSMITTER

Parameter	Symbol	Min	Typ	Max	Unit	Remarks
Output Optical Power	P <sub>TX</sub>	-15		-8	dBm	Average, coupled into 9/125um SMF
Extinction ratio	E <sub>r</sub>	9			dB	
Optical Center Wavelength	λ <sub>C</sub>	1260	1310	1360	nm	
Spectral Width (RMS)	Δλ			4	nm	
Rise/Fall Time	t <sub>r</sub> /t <sub>f</sub>			3	nsec	20% to 80%
Total Jitter	t <sub>J</sub>			1.0	nsec	
Output Optical Eye	Compliant with IEEE 802.3-2002					
TX-DISABLE Assert Time	t <sub>off</sub>			10	μsec	Average
Launch Power OFF	P <sub>off</sub>			-45	dBm	Average

## OPTICAL CHARACTERISTICS – RECEIVER

Parameter	Symbol	Min	Typ	Max	Unit	Remarks
Optical Receiver Power	P <sub>RX</sub>			-8	dBm	Average
Optical Center Wavelength	λ <sub>C</sub>	1200		1600	nm	
Receiver Sensitivity	R <sub>X_SENS</sub>			-32	dBm	BER<10 <sup>-12</sup> , PRBS 2 <sup>7</sup> -1
Loss of Signal-Asserted	P <sub>LOS_A</sub>	-45			dBm	
Loss of Signal-Deasserted	P <sub>LOS_D</sub>			-33	dBm	
Optical Return Loss	ORL	12			dB	
LOS Hysteresis		1		3	dB	

Subject to change without notice.

For more information, visit [smartoptics.com](http://smartoptics.com).

### ELECTRICAL CHARACTERISTICS – HIGH-SPEED SIGNAL INTERFACE (CML)

Parameter	Symbol	Min	Typ	Max	Unit	Remarks
Differential Input Impedance	$R_{IN}$	85	100	115	$\Omega$	
Differential data input swing	$V_{IN\_PP}$	400		2000	mVpp	Internally AC coupled
Differential Output Impedance	$R_{OUT}$	85	100	115	$\Omega$	
Differential data output swing	$V_{OUT\_PP}$	400		2000	mVpp	Internally AC coupled

### ELECTRICAL CHARACTERISTICS – LOW-SPEED SIGNAL INTERFACE (LVTTTL)

Parameter	Symbol	Min	Typ	Max	Unit	Remarks
Input High Voltage		2.0		$V_{CC}+0.3$	V	TX-DIS, TX-FAULT
Input Low Voltage		GND		0.8	V	
Output High Voltage		2.0		$V_{CC}+0.3$	V	RX-LOS
Output Low Voltage		GND		0.5	V	

### FUNCTIONAL DIAGRAM OF TRANSCEIVER

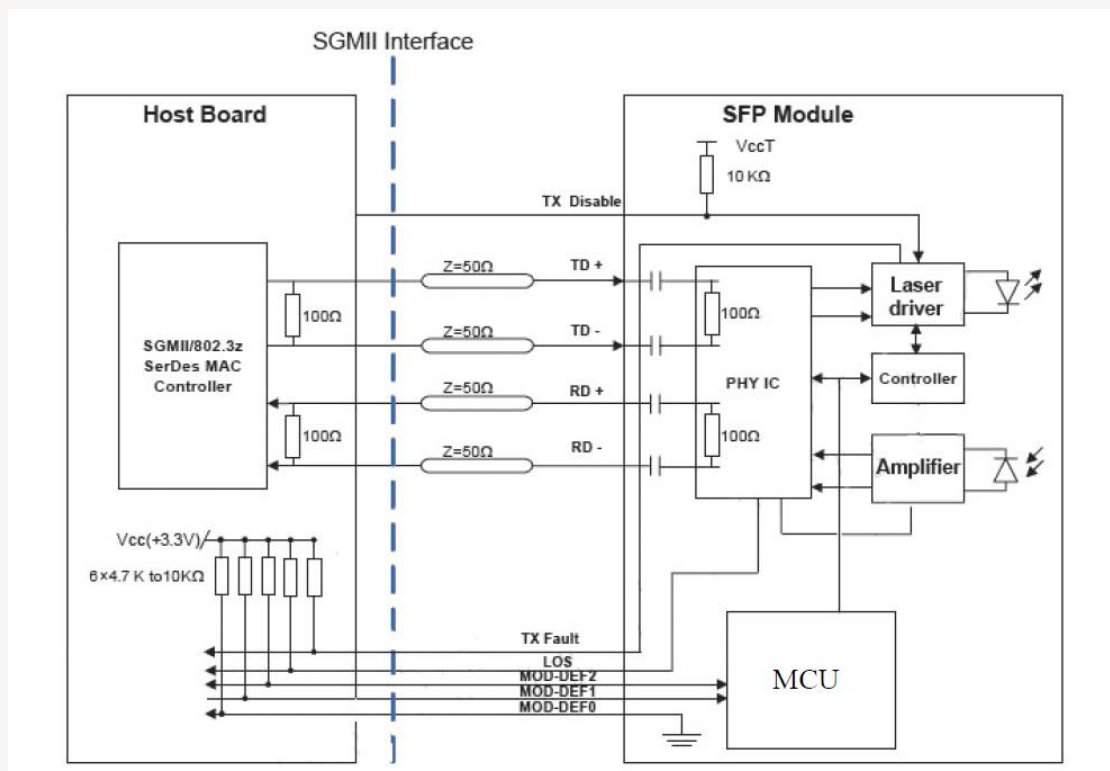

## PIN ASSIGNMENT ACCORDING TO MSA

PIN	Signal Name	Description	PIN	Signal Name	Description
1	V <sub>EE</sub> T	Transmitter Signal Ground	11	V <sub>EE</sub> R	Receiver Signal Ground
2	TX_Fault	Transmitter Fault Indication. Logic "1" Output = Laser Fault. Logic "0" Output = Normal Operation	12	RD-	Inverse Receiver Data Out
3	TX_Disable	Logic "1" Input (or no connection) = Laser off, Logic "0" = Laser on.	13	RD+	Receiver Data Out
4	SDA	Modulation Definition 2 – Two wires serial ID Interface	14	V <sub>EE</sub> R	Receiver Signal Ground
5	SDL	Modulation Definition 1 – Two wires serial ID Interface	15	V <sub>CC</sub> R	Receiver Power – 3.3V±5%
6	MOD-ABS	Modulation Definition 0 – Ground in Module	16	V <sub>CC</sub> T	Transmitter Power – 3.3V±5%
7	RS0	RX Rate Select (LVTTTL). This pin has an internal 30k pull-down to ground. A signal on this pin will not affect module performance.	17	V <sub>EE</sub> T	Transmitter Signal Ground
8	RX_LOS	Loss of Signal Out (OC).	18	TD+	Transmitter Data In
9	RS1	TX Rate Select (LVTTTL). This pin has an internal 30k pull-down to ground. A signal on this pin will not affect module performance.	19	TD-	Inverse Transmitter Data In
10	V <sub>EE</sub> R	Receiver Signal Ground	20	V <sub>EE</sub> T	Transmitter Signal Ground

## MECHANICAL DIMENSIONS

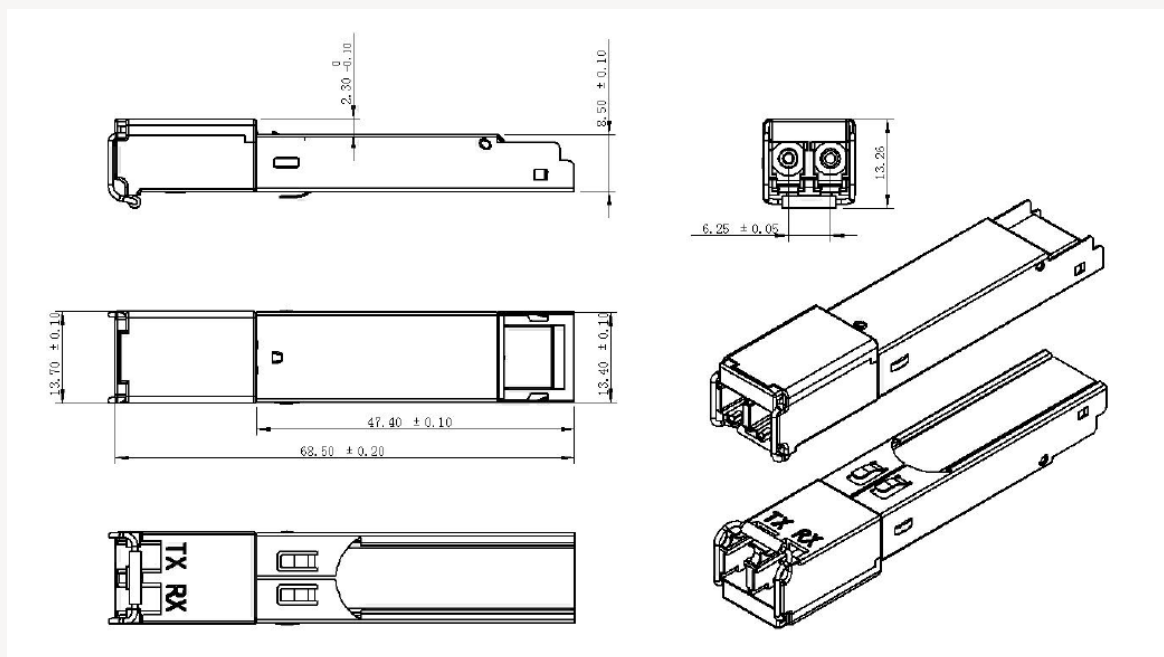

Subject to change without notice.

For more information, visit [smartoptics.com](http://smartoptics.com).