

SO-SFP-100BASE-BX20D-34

SFP BIDI, 100/155Mbps, TX/RX=1310/1490nm, SM, DDM, 13dB, 20km, LC

OVERVIEW

The SO-SFP-100Base-BX20D-34 series is small form factor pluggable module for IEEE 802.3ah 100BASE-BX10 and OC-3/STM-1 SONET/SDH single fiber applications by using 1310 nm/1490nm transmitter and 1490nm/1310nm receiver. It is with the SFP 20-pin connector to allow hot plug capability. The transmitter section uses a multiple quantum well A type / B type laser and is a class 1 laser compliant according to International Safety Standard IEC 60825. The receiver section uses an integrated A type/ B type detector preamplifier (IDP) mounted in an optical header and a limiting post-amplifier IC. The SO-SFP-100Base-BX20D-34 series are designed to be compliant with SFF-8472.

PRODUCT FEATURES

- Support 155Mbps data links
- A type: 1310nm FP TX / 1490nm RX
- 20km with 9/125 μ m SMF
- Single 3.3V power supply and TTL logic interface
- Hot-Pluggable SFP footprint simplex LC connector interface
- Class 1 FDA and IEC60825-1 laser safety compliant
- Operating case temperature
 - Standard: 0°C ~ +70°C
 - Industrial: -40°C ~ +85°C
- Compliant with SFP MSA Specification
- Compliant with SFF-8472 MSA

APPLICATIONS

- SONET OC-3 / SDH STM-1
- WDM fast Ethernet links
- Single fiber optical networking

ORDERING INFORMATION

Part Number	Description
SO-SFP-100Base-BX20D-34	SFP BIDI, 100/155Mbps, TX/RX=1310/1490nm, SM, DDM, 13dB, 20km, LC
SO-SFP-100Base-BX20D-34-I	SFP BIDI, 100/155Mbps, TX/RX=1310/1490nm, SM, DDM, 13dB, 20km, LC, ind. temp

ABSOLUTE MAXIMUM RATINGS

Parameter	Symbol	Min	Max	Unit
Storage Temperature	TS	-40	+85	°C
Supply Voltage	VCC	-0.5	3.6	V
Operating Relative Humidity			95	%

RECOMMENDED OPERATING CONDITIONS

Parameter	Symbol	Min	Typ	Max	Unit
Case Operating Temperature	TA	SO-SFP-MR155-BX20D-34		+70	°C
		SO-SFP-MR155-BX20D-34-I	-40	+85	
Power Supply Voltage	Vcc	3.15	3.3	3.45	V
Power Supply Current	Icc			300	mA
Data rate	OC-3		155		Mbps
		100M	100		

PERFORMANCE SPECIFICATIONS – ELECTRICAL TRANSMITTER

Parameter	Symbol	Min	Typ	Max	Unit	Notes
LVPECL Compatible Inputs(Differential)	V _{IN}	400		2000	mVpp	AC coupled inputs
Input Impedance (Differential)	Z _{IN}	85	100	115	ohms	R _{in} > 100 kohms @ DC
TX Disable	Disable	2		Vcc	V	
	Enable	0		0.8		
TX FAULT	Fault	2		Vcc+0.3	V	
	Normal	0		0.5		

PERFORMANCE SPECIFICATIONS – ELECTRICAL RECEIVER

Parameter	Symbol	Min	Typ	Max	Unit	Notes
LVPECL Outputs (Differential)	V _{out}	400		2000	mVpp	AC coupled outputs
Output Impedance (Differential)	Z _{out}	85	100	115	ohms	
Rx_LOS Output Voltage – High		2		Vcc+0.3	V	
Rx_LOS Output Voltage – Low		0		0.8	V	
MOD_DEF (2:0)	VoH	2.5			V	With Serial ID
	VoL	0		0.5	V	

OPTICAL AND ELECTRICAL CHARACTERISTICS

Parameter	Symbol	Min	Typ	Max	Unit
9µm Core Diameter MMF	L		20		km
Data Rate		100	155		Mbps

OPTICAL AND ELECTRICAL CHARACTERISTICS TRANSMITTER

Parameter	Symbol	Min	Typ	Max	Unit
Centre Wavelength	λ_c	1260	1310	1360	nm
Spectral Width (RMS)	$\Delta\lambda$			4	nm
Average Output Power	P_{out}	-15		-8	dBm
Extinction Ratio	ER	8.2			dB
Rise/Fall Time(20%~80%)	t_r/t_f			2	ps
Output Optical Eye		IUT-T G.957 Compliant			
TX Disable Assert Time	t_{off}			10	us
Pout@TX Disable Asserted	P_{out}			-45	dBm

OPTICAL AND ELECTRICAL CHARACTERISTICS RECEIVER

Parameter	Symbol	Min	Typ	Max	Unit
Centre Wavelength	λ	1480	1490	1500	nm
Receiver Sensitivity	P_{min}	OC-3		-28	dBm
		100M		-29	dBm
Receiver Overload	P_{max}	-8			dBm
LOS De-Assert	LOSD			-30	dBm
LOS Assert	LOSA	-42			dBm
LOS Hysteresis		0.5			dB

PIN ASSIGNMENT ACCORDING TO MSA

PIN	Signal Name	Description	PIN	Signal Name	Description
1	V _{EE} T	Transmitter Signal Ground	11	V _{EE} R	Receiver Signal Ground
2	TX_Fault	Transmitter Fault Indication. Logic "1" Output = Laser Fault. Logic "0" Output = Normal Operation	12	RD-	Inverse Receiver Data Out
3	TX_Disable	Logic "1" Input (or no connection) = Laser off, Logic "0" = Laser on.	13	RD+	Receiver Data Out
4	SDA	Modulation Definition 2 – Two wires serial ID Interface	14	V _{EE} R	Receiver Signal Ground
5	SDL	Modulation Definition 1 – Two wires serial ID Interface	15	V _{CC} R	Receiver Power – 3.3V±5%
6	MOD-ABS	Modulation Definition 0 – Ground in Module	16	V _{CC} T	Transmitter Power – 3.3V±5%
7	RS0	RX Rate Select (LVTTL). This pin has an internal 30k pull-down to ground. A signal on this pin will not affect module performance.	17	V _{EE} T	Transmitter Signal Ground
8	RX_LOS	Loss of Signal Out (OC).	18	TD+	Transmitter Data In
9	RS1	TX Rate Select (LVTTL). This pin has an internal 30k pull-down to ground. A signal on this pin will not affect module performance.	19	TD-	Inverse Transmitter Data In
10	V _{EE} R	Receiver Signal Ground	20	V _{EE} T	Transmitter Signal Ground

MECHANICAL DIMENSIONS

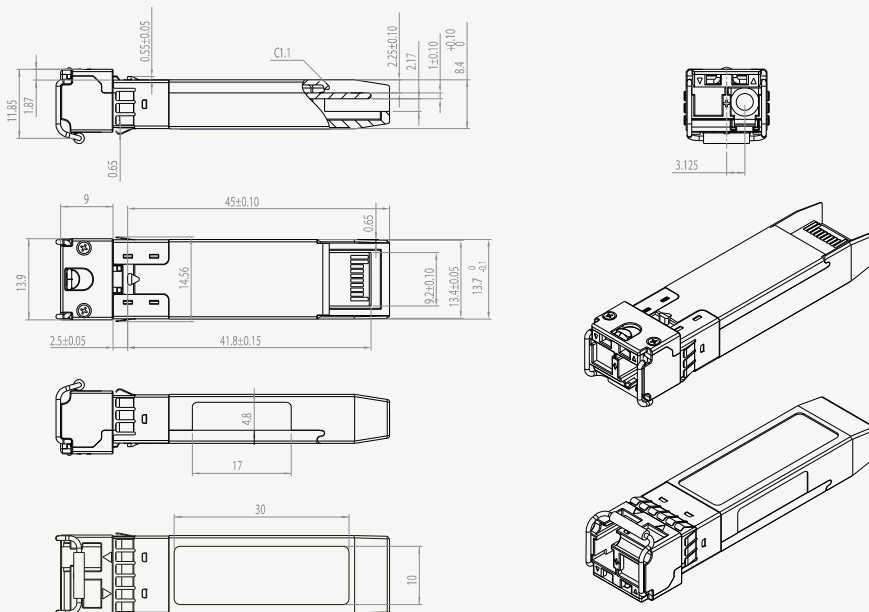

Subject to change without notice.

For more information, visit smartoptics.com.